

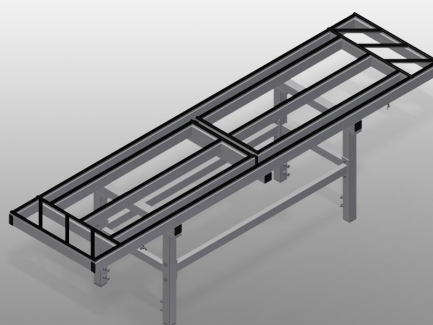

# MSA

## Assembly tables



Assembly station for all assembly tasks on special-order elements and curtain walls. Stable steel construction. Assembly table for all assembly tasks on special-order elements and curtain walls. Pull-outs on two sides. Assembly table is ideal for the assembly of larger elements. The narrow design of the machine base provides good accessibility to the elements from all sides. The assembly table is mobile. Supporting surfaces with rubber profile. The tables can be adapted to suit the elements optimally due to a large adjustment range of the supporting surfaces, i.e. by pulling out the supports and shifting the tables. Variants for assembly lines: the rails, once adjusted to be level, provide a level supporting surface on which the tables can be moved; the tables can be moved and easily positioned on the rails; two or more tables can be combined to enlarge the supporting surface to any extent desired; the tables are ideal for the assembly of large elements; when the tables are not needed, they can be pushed together and moved aside; there are supports with a parallelogram shape at the edges to allow profiles to be set down longitudinally. Stand-alone variants: the narrow design of the machine base provides good accessibility to the elements from all sides; a larger work area of the supporting surface can be achieved by pulling out the parallelogram-shaped supports; the tables can be moved and easily positioned on castors; two tables can be combined to enlarge the supporting surface to any extent desired; the tables are ideal for the assembly of large elements.



### Supporting surfaces

Supporting surfaces equipped with rubber profile to protect profiles from damage

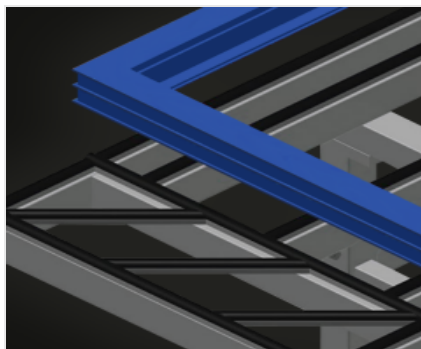

### Supports

Supporting surfaces with rubber profile. The supports at the edges have a parallelogram shape to allow profiles to be set down longitudinally. Pull-out supports on the side: 900 mm

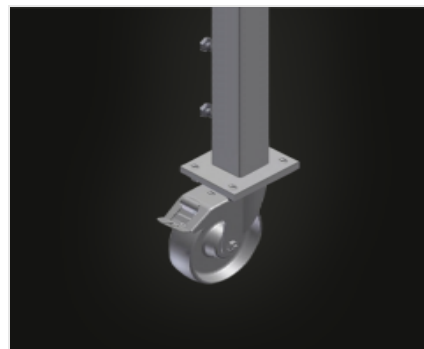

### Casters (Optional)

Mobile unit: two casters with brake and two fixed rollers provide mobility in all directions



### Flanged rollers, cmpl. (Optional)

Mobility unit with four flanged rollers and two fixing brakes

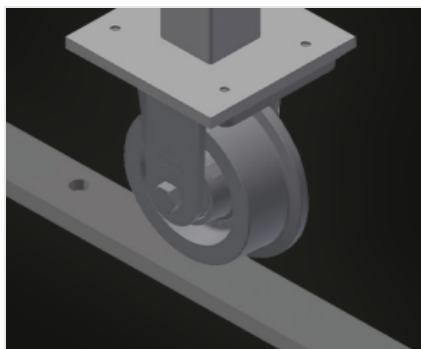

### Rails (Optional)

Rails, 2.0 m, left and right

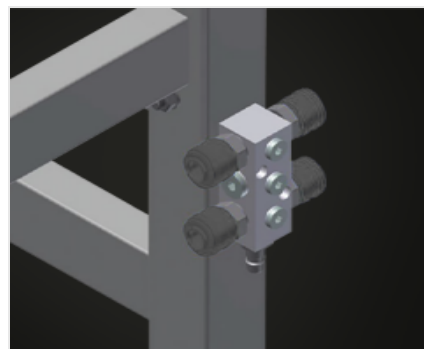

### 4-fold compressed air connection (Optional)

4-fold compressed air connection for connecting compressed-air tools



MODELS

MSA 2400



DIMENSION AND WEIGHT

Length (mm)	2.400
Width (mm)	600
Height (mm)	850 ÷ 1.000
Weight (kg)	80

SUPPORTING SURFACE

Supporting surface (mm)	600 x 2.400
Supporting surface with pulled out sides (mm)	600 x 4.200
Load capacity (kg)	600

CHARACTERISTICS

Shelf	<input type="radio"/>
4-fold compressed air supply	<input type="radio"/>
Castor wheel Stand Alone (2 castors + 2 fixed)	<input type="radio"/>
Roller for rail system	<input type="radio"/>
Rail 2,0 m left and right	<input type="radio"/>

Included ● Available ○