

**FFR 10**

## Rack systems



Rack for storage of window elements. Stable steel construction. Rack for storage of window sashes. The individual elements are available for direct access. Specially designed for integration in assembly lines. Access is possible from both sides. Supporting surfaces with support rollers for even easier loading and unloading. Compartment separating bars covered with protective tubing. Options: mobile as trolley on request - RFR 10/FFR 10; profile protectors for support rollers (alum.).

**Compartments**

All supporting surfaces have a non-slip PVC cladding which protects surfaces from damage during storage

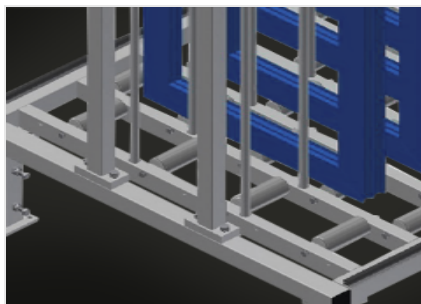
**Supports**

Lower storage area with support rollers for easier loading and unloading

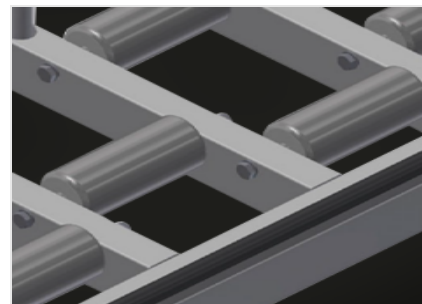
**Profile protectors**

Profile protectors for support rollers 3x120 mm (Alum./48 x), support rollers covered with protective tubing

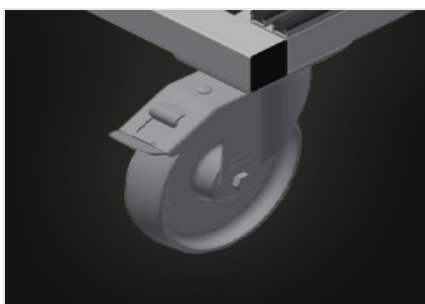
**Casters, cmpl.  
(Optional)**

Two casters with brake and two fixed rollers provide mobility in all directions, roller diameter 125 mm



CHARACTERISTICS

Length (mm)	1.820
Width (mm)	1.000
Height (mm)	2.965
Compartments	10
Compartment width (mm)	130
Compartment height (mm)	2.600
Weight (kg)	250
Load capacity (kg)	800
Floor support equipped with knob profile	●
Compartment separating bars covered with protective tubing	●
Supporting surface with rollers	●
Rollers and handle	○

Included ● Available ○